

**OPERATING INSTRUCTIONS
BEDIENUNGSANLEITUNG
MANUALE D'ISTRUZIONI**

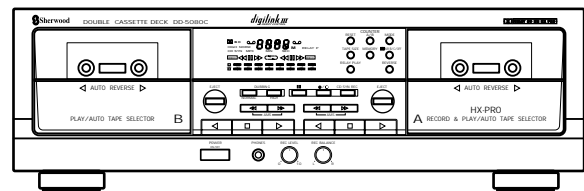

DD-5080C

*Double Cassette Deck
Doppel Cassetten Recorder
Registratore Stereo a Doppia Piastra*



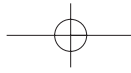

Unpacking and installation

ENGLISH

Congratulations on your purchase!

Your new high fidelity Integrated Cassette Deck is designed to deliver maximum enjoyment and years of trouble free service. Please take a few moments to read this manual thoroughly. It will explain the features and operation of your Unit and help a trouble free installation.

Please unpack your Cassette Deck carefully. We recommend that you save the carton and packing material. They will be helpful if you ever need to move your unit and may be required if you ever need to return it for service. Your Cassette Deck is designed to be placed in a horizontal position and it is important to allow at least two inches of space behind your unit for adequate ventilation and cabling convenience.

To avoid early damage, never place the unit near radiators, in front of heating vents, in direct sunlight, or in excessively humid or dusty location.

Connect your complementary components as illustrated in the following section.

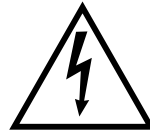

This symbol is intended to alert the user to the presence of unisulated "dangerous voltage" within the product's enclosure that may be of sufficient magnitude to constitute a risk of electric shock to persons.



This symbol is intended to alert the user to the presence of important operating and maintenance (servicing) instructions in the literature accompanying the appliance.

CAUTION

To prevent electric shock, do not use this(polarzed) plug with an extension cord, receptacle or other outlet unless the blades can be fully inserted to prevent blade exposure.

WARNING

To prevent fire or shock hazard, do not expose the unit to rain or moisture.



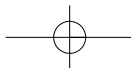

Read this Before Operating Your Unit

FOR THE U.S.A. AND CANADA 120 V

FOR AUSTRALIA AND EUROPE ... 220 V/230 V/240 V

FOR YOUR SAFETY

Units shipped to the U.S.A. and Canada are designed for operation on 120 V AC only.

Safety precaution for a polarized AC plug. However, some products may be supplied with a non-polarized plug.

CAUTION : To prevent electric shock, do not use this (polarized) plug with an extension cord, receptacle or other outlet unless the blades can be fully inserted to prevent blade exposure.

FOR YOUR SAFETY

Units shipped to Australia are designed for operation on 240 V AC only. To ensure safe operation the three-pin plug supplied must be inserted only into a standard three-pin power point which is effectively earthed through the normal household wiring. Extension cords used with the equipment must be three-core and be correctly wired to provide connection to earth. Wrongly wired extension cords are a major cause of fatalities. The fact that the equipment operates satisfactorily does not imply that the power point is earthed and that the installation is completely safe. For your safety, if in any doubt about the effective earthing of the power point, consult a qualified electrician.

PAN-EUROPEAN UNIFIED VOLTAGE
All units are suitable for use on supplies 220-240 V AC.

ENGLISH

FOR OTHER COUNTRIES 110 V/220 V

FOR YOUR SAFETY

Units shipped to countries other than the above countries are equipped with an AC voltage selector switch on the rear panel. Refer to the following paragraph for the proper setting of this switch.

AC VOLTAGE SELECTION
This unit operates on 110-220 V AC. The AC voltage selector switch on the rear panel is set to the voltage that prevails in the area to which the unit is shipped. Before connecting the power cord to your AC outlet, make sure that the setting position of this switch matches your line voltage. If not, it must be set to your voltage in accordance with the following direction.

AC voltage selector switch

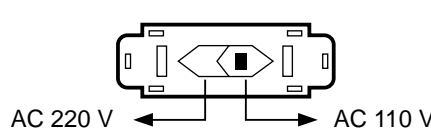

Move switch lever to match your line voltage with a small screwdriver or other pointed tool.

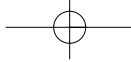

Rear Panel Connections

- Do not plug the AC input cord into the AC outlet when making connections.
- Be sure to connect the white plugs to the L(Left) and the red plugs to the R(Right) jacks when making connections.

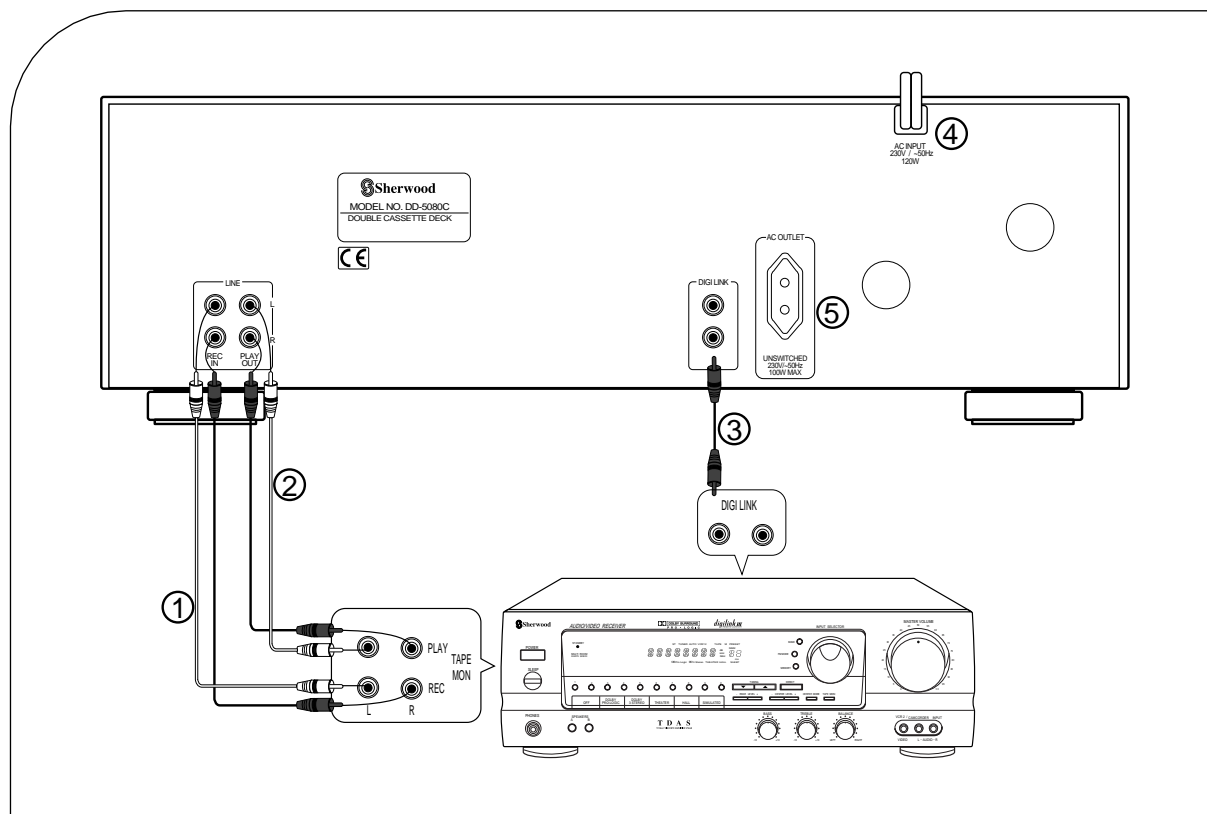

REC INPUT JACKS

Connect the cords between the REC INPUT jacks of this unit and the REC OUTPUT jacks of your amplifier.

PLAY OUTPUT JACKS

Connect the cords between the PLAY OUTPUT jacks of this unit and the PLAY INPUT jacks of your amplifier.

DIGI LINK JACKS

Connect this jack to the DIGI LINK jack of Sherwood component such as R125, R325, etc., bearing the DIGI LINK or mark to control this unit remotely by DIGI LINK system.

AC INPUT CORD

Plug this cord into the switched AC outlet of amplifier or a household AC outlet.

UNSWITCHED AC OUTLET (REGIONAL OPTION)

Power always flows to this outlet, regardless of whether this unit is switched ON or OFF if power flows through the AC input cord of this unit.

NOTE : The equipment whose power consumption exceeds 100 watts should not be connected.

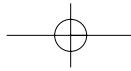

Front Panel Controls

ENGLISH

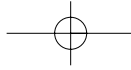
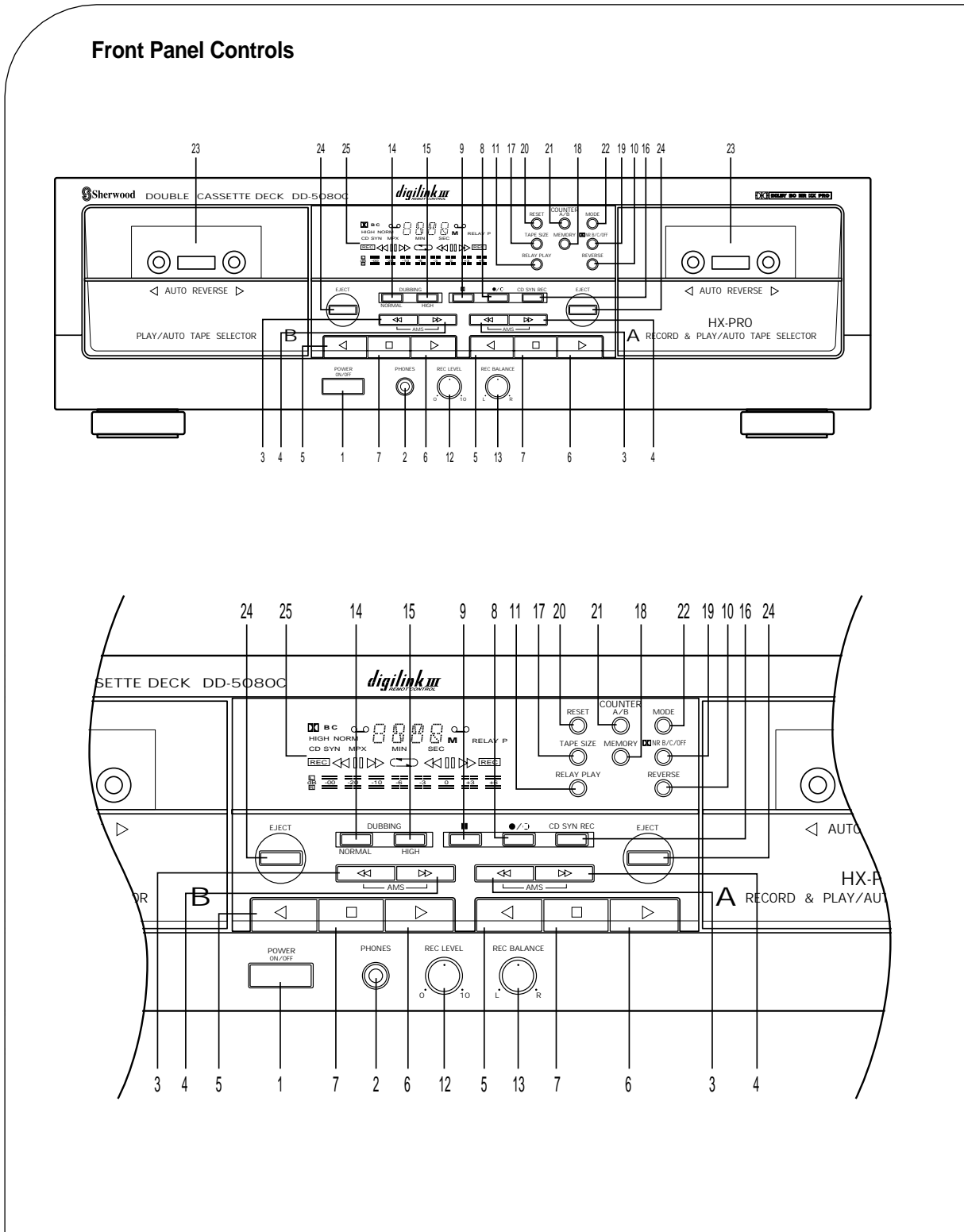

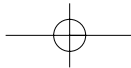
**POWER SWITCH**

Press this switch to turn the power on and press again to turn the power off.

For system operation, plug the AC input cord into the switched AC outlet on amplifier or receiver, keep the POWER switch ON and control power ON/OFF with the main POWER switch on the amplifier or receiver.

HEADPHONE JACK

Stereo headphones with a standard 1/4 inch plug can be plugged into this jack for private listening.

REWIND and FAST FORWARD**BUTTONS(and)**

Press the button to rewind or advance the tape rapidly.

For AMS (Automatic Music Search), press this button during playback.

REVERSE PLAY BUTTON ()

Press this button to play back the reverse side of the tape.

FORWARD PLAY BUTTON()

Press this button to play back the forward side of the tape.

STOP BUTTON ()

Press this button to stop a tape.

RECORD/RECORD MUTING BUTTON**(/ □) (DECK A only)**

Press this button and this unit will be in recording pause mode. To start recording, press the FORWARD PLAY or REVERSE PLAY button.

PAUSE BUTTON () (DECK A only)

Press this button to temporarily stop playing back or recording or dubbing.

To restart the tape, Press the PLAY button.

REVERSE MODE BUTTON

Press this button to select the desired reverse mode when playing back or recording.

RELAY PLAY BUTTON

Press this button and the deck relays to play from Deck A to Deck B or vice versa.

Use this function with the REVERSE MODE button.

REC LEVEL CONTROL

Use this control to adjust the recording level.

REC BALANCE CONTROL

Use this control to adjust the balance of the right and left recording level.

NORMAL SPEED DUBBING BUTTON

Press this button to set to Normal Speed Dubbing Mode.

HIGH SPEED DUBBING BUTTON

Press this button to set to High Speed Dubbing Mode.

CD SYNCHRO RECORDING BUTTON

Press this button to use the CD SYNCHRO RECORDING function.

TAPE SIZE BUTTON

Press this button to select the tape length for displaying the elapsed time when playing back or recording.

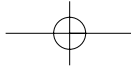

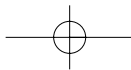

MEMORY BUTTON

Press this button to memorize the specific point on the tape.

NR B/C/OFF BUTTON

Press this button to select the Dolby B type or C type NR system when playing back or recording.

COUNTER RESET BUTTON

Press this button to reset the counter to "0000" or "00 min. 00 sec."

) DECK A/B COUNTER SELECTOR BUTTON

Press this button to select which deck to be counted.

The tape detection indicator blinks 4 times.

) COUNTER MODE BUTTON

Press this button to select the tape or time counter mode.

) CASSETTE DOOR

Press the EJECT button of the corresponding DECK to open the cassette door when the deck is in the stop mode.

The door can be easily dismantled by pushing it up and then taking it out toward the front after opening the door.

) EJECT BUTTON

Press this button to open the cassette door.

) FLUORESCENT DISPLAY

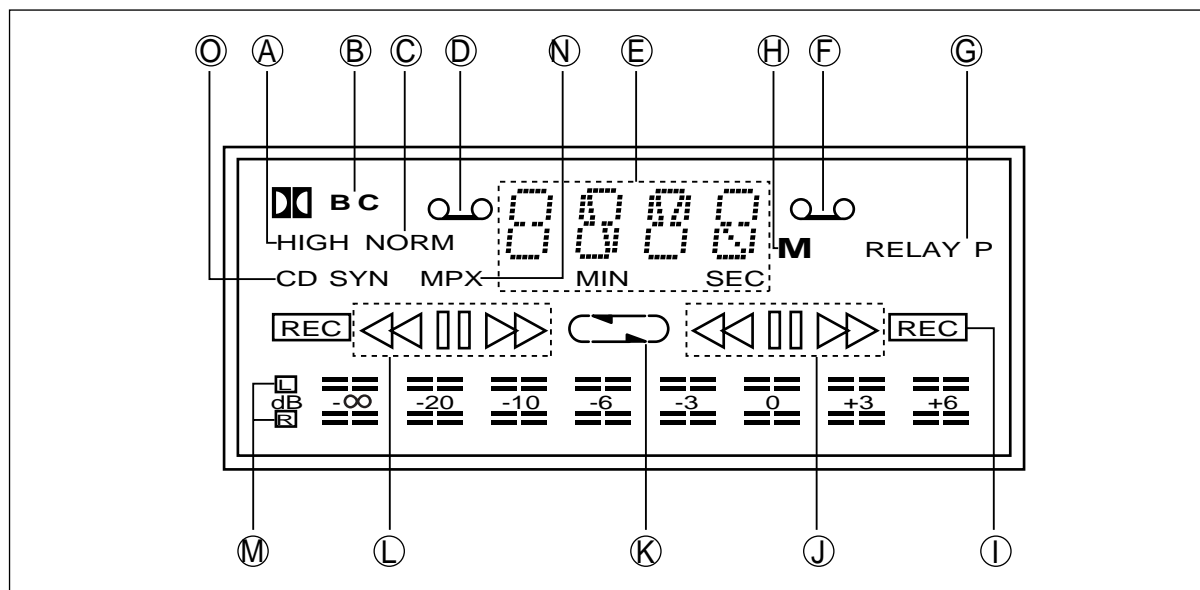

HIGH SPEED DUBBING INDICATOR
 DOLBY NR INDICATORS
 NORMAL SPEED DUBBING INDICATOR
 DECK B TAPE DETECTION INDICATOR
 COUNTER DISPLAY
 DECK A TAPE DETECTION INDICATOR
 RELAY PLAY INDICATOR
 MEMORY INDICATOR

RECORDING INDECATOR
 DECK A TAPE TRANSPORT INDICATORS
 REVERSE MODE INDICATOR
 DECK B TAPE TRANSPORT INDICATORS
 LEVEL METER DISPLAY
 MPX FILTER INDICATOR
 CD SYNCHRO RECORDING INDICATOR

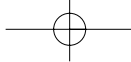

Operations

PLAYING BACK TAPES

ENGLISH

1

Press the POWER switch to turn the power on.



- Don't turn the power off while operating the unit.

2

Insert the cassette with exposed tape side facing down. To close the cassette door, push the door until it locks shut

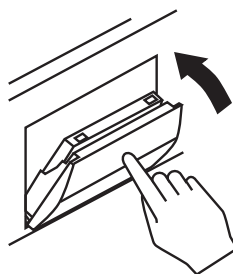

- According to the type of the tape loaded, you will see the following display(Auto Tape Selector).

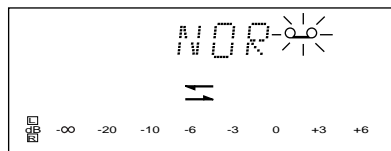

Normal tape : "NOR" is displayed.

Chrome tape : "CR" is displayed.

Metal tape : "ME" is displayed.

- The type of a tape loaded is detected automatically by the auto tape selector and recording bias and equalization are set automatically according to the characteristics of the tape such as normal, chrome or metal tape.

3

If the tape is recorded with Dolby NR system, select the corresponding Dolby NR system.

NR B/C/OFF



- Each time this button is pressed, the Dolby NR system changes as follows;

DOLBY B DOLBY C OFF

- On commercial pre recorded cassette tapes, if Dolby NR or  appears but Dolby C is not specified, the tapes are recorded with the Dolby B NR.

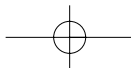

4

Select your desired reverse mode.



- Each time REVERSE MODE button is pressed. Mode changes as follows;

- : One side play or recording.
(Side A STOP, Side B STOP)
- : Side A Side B STOP
Side B Side A STOP
- : Continuous Auto Reverse Mode
(Side A Side B Side A ...)

- To use relay play, load the cassette tapes into DECK A and B and press the RELAY PLAY button.



- The relay patterns are different according to the reverse mode. Refer to the followings.
Example : When starting the forward playback at DECK B.

- : Deck B(Side A)
Deck A(Side A)
- : Deck B(Side A Side B)
Deck A(Side A Side B)
- : Deck B(Side A side B)
Deck A(Side A Side B)
Deck B.....(continuous relay play)

5

Start playback.

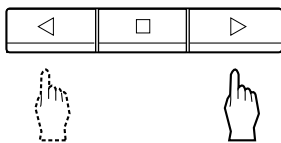

6

To stop playback.

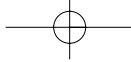
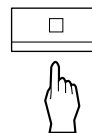

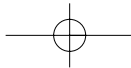

MUSIC SEARCH PROGRAMMING

- The automatic music search function automatically skips other programs, finds and starts playback from the desired program.
Up to 20th program before or after the present program can be searched quickly.
- During playback, press the button the desired number of times.

Example : When listening to the second program before or after the present program.

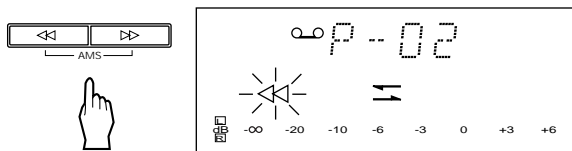

The second program can be searched quickly and and played back.

* Automatic music search function might not operate as expected if:

- The length of the blank space between two musics is less than 4 seconds.
- The noise level of the blank space is very high.
- The overall recorded volume level of a program is very low.

RECORDING

1

Load a tape to be recorded into DECK A.



- Be sure the erase-protection tabs on the cassette tapes are in place.

2

Select the reverse mode.









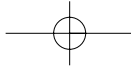

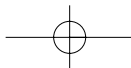
 : Recording of a single side.

 : Recording of both sides.

- When selecting recording of both sides and recording first on the reverse side, recording is made only on that side.



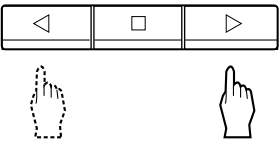
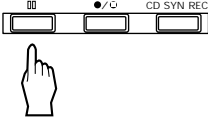
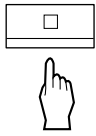

<p>3 When recording with DOLBY NR system, select the desired DOLBY NR system.</p> 	<p>4 Select the program source to be recorded. Example : When selecting the tuner.</p>
<p>5 Press the RECORD/RECORD MUTING button to enter the recording pause mode.</p>  <p>  : Recordable on both sides  : Recordable on front side  : Recordable on back side </p>	<p>6 Adjust the recording level with the REC LEVEL control. (see page 12)</p> 
<p>7 Adjust the balance of the right and left recording level with the REC BALANCE control.</p>  <ul style="list-style-type: none"> • In general, set this control to the center position. • Listen to the program source and adjust the recording level and the balance. 	<p>8 Press the PLAY button to start recording.</p> 
<p>9 To temporarily stop recording.</p>  <ul style="list-style-type: none"> • To restart recording, press the corresponding PLAY button. 	<p>10 To stop recording.</p> 

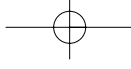

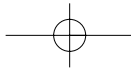

RECORDING LEVEL ADJUSTMENT

- The most important factor for good recording result is the recording level adjustment. If the recording level is set at maximum, the signal-to-noise ratio (S/N) and the dynamic range (range of sound volume) will improve, but if it is set too high, the sound quality will deteriorate. On the contrary when the recording level is set too low in order to avoid distortion, tape hiss noise becomes too evident. Even among tapes of the same type, the tape characteristics may differ according to maker and kind. It is therefore important to determine the optimum recording level for each tape used, in order to obtain good recordings by fully utilizing the tape characteristics.
- The optimum recording level depends on the type of music to be recorded and also on the type of tape used.
- Generally, adjust the recording level so that the level meters indicate around the 0 dB point for normal or chrome tapes or the +3 dB point for metal tapes at the highest signal level.

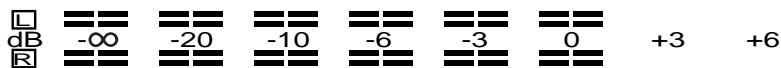

- Proper setting for normal or chrome tapes.



- Proper setting for metal tapes.

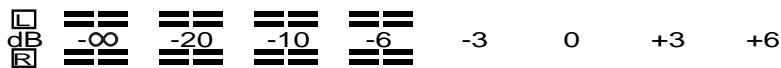

- Too low of setting, too noise.



- Too high of setting, distorted sound.

MAKING A BLANK SPACE

- In the recording pause mode, press the RECORD/RECORD MUTING button again.



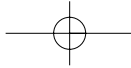

- The unit will make 4 seconds of blank space, then enter the recording pause mode.

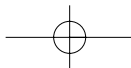



RECORDING A CD AUTOMATICALLY



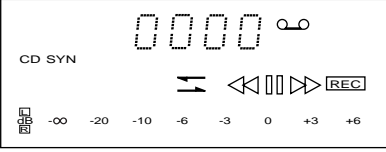

- When this unit is connected to a Sherwood DIGI LINK CD player controlled remotely by the DIGI LINK system, the CD Synchro record function can be operated.
- Before starting CD synchro recording, adjust the recording level and the balance.

<p>1 Repeat steps 1,2,3 and 4 of "RECORDING" Procedure.</p>	<p>2 According to the tape length edit the tracks to be recorded on the CD player referring to the operating instructions of that.</p>
<p>3 Start CD synchro recording.</p> <div style="display: flex; align-items: center; justify-content: center;"> <div style="margin-right: 20px;">  <p>CD SYN REC</p>  </div> <div style="border: 1px solid black; padding: 5px;">  </div> </div> <ul style="list-style-type: none"> • The CD is selected automatically on the amplifier DIGI LINK receiver. • If 8 seconds elapses after starting recording, the CD player starts play automatically. 	

NOTE

- Only when the erase protection taps on the cassette tapes are in place, CD synchro record function will be operated.
- During CD synchro recording, if other program source on the receiver is selected, the unit stops CD synchro recording and starts recording the selected program source.

DUBBING FROM DECK B to DECK A

<p>1 Open the cassette door by pressing the EJECT button and load a blank cassette tape into DECK A and prerecorded cassette tape into DECK B.</p>	<p>2 Select the reverse mode</p> <div style="text-align: center;">  <p>REVERSE</p>  </div> <p style="text-align: center;">  : Recording of a single side.  : Recording of both sides. </p>
---	---

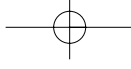

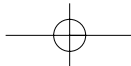

ENGLISH

3 Press the DUBBING MODE button to select the normal or high speed(1.5 times normal speed) dubbing.

- High quality sound will be obtained in the normal speed dubbing mode.

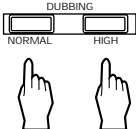

- Then dubbing will start.

4 To stop dubbing.

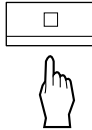

NOTE

- During dubbing, the Dolby NR is automatically set to OFF and the recorded tape can be dubbed as it is.
- During dubbing, do not change the speed. If so, tape click noise may be recorded.
- During dubbing, the settings of the REC LEVEL and the REC BALANCE controls are ignored.

SELECTING A COUNTER MODE

There are two kinds of counter mode: tape counter, time counter for displaying the elapsed recording or playback time.

- Select the desired counter mode.

Example : When selecting the time counter.



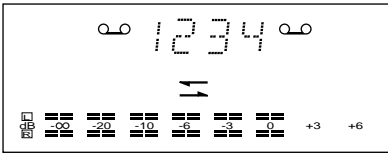

TAPES COUNTER mode

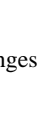

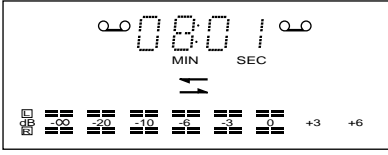

TIME COUNTER mode

- Each time this button is pressed, the counter mode changes as follows;

TAPES COUNTER TIME COUNTER

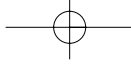

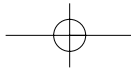

SELECTING A TAPE LENGTH

- Select the corresponding tape length according to the loaded tape.

Example : In case of 60 minute tape.

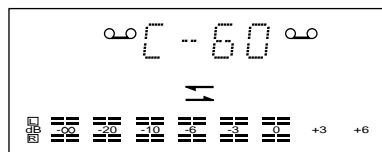

- Each time this button is pressed, the tape length changes as follows;

C-60 C-90 C120

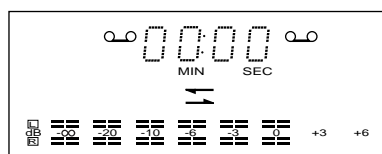

- During playback or recording, the elapsed recording or playback time are displayed.
- The time counter is not actually a clock so that the displayed time is not exactly equal to the actual elapsed time.

RESETTING TO "0000" OR "00 min. 00 sec."

- In each counter mode, press the COUNTER RESET button to reset to "0000" or "00 min. 00 sec".

Example : In the tape counter mode.

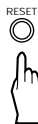

1234 → 0000

MEMORIZING THE SPECIFIC POINT

Press the MEMORY button to memorize the desired counter number or time.

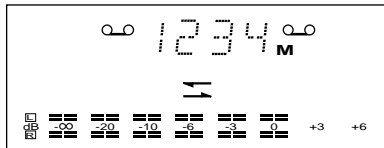

- The unit will automatically returns to the memorized position when the FAST FORWARD or REWIND button is pressed.
- This function is helpful to listen to the desired intervals repeatedly.
- Press again to cancel.

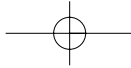

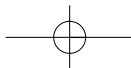

DOLBY HX PROFESSIONAL HEAD ROOM EXTENSION(DOLBY HX PRO)

ENGLISH

1. Dolby HX PRO is a professional recording bias system which are now available in some home cassette recorders that improving dynamic range and signal clarity for life-like sound quality.

When recording audio signals which contain high-frequency components, these components influence the bias and decrease the high recording frequencies. (If the amount of the bias is high, high frequencies are decreased, while the amount of the bias is low, high frequencies are increased, resulting in high distortion.)

The Dolby HX Pro system responds to high or low frequencies to regulate the oscilation of the bias level added to the recording head, thus providing a stable, effective bias to the audio signals being recorded.

When an audio signal contains a large number of high-frequency components, the bias is held to a low value and deterioration of high frequencies is avoided, where as for low frequencies, the bias is added at a fixed rate.

Bias is thus added at the optimum rate for both high and low frequencies.

2. The unit incorporates the Dolby HX Pro system which automatically adjusts the bias for nomal, CrO₂, and metal tapes at both channels independently. Since the system is automatically engaged during the recording process only, the audiophile can enjoy the full benefits of any tape without worrying about proper adjustment of switches and encoding/decoding controls.

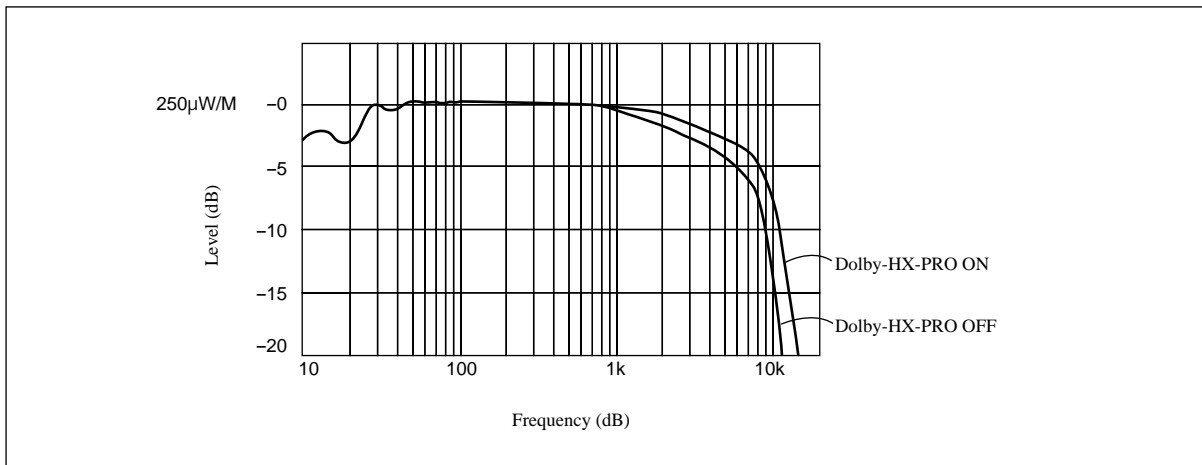

PRINCIPLE OF DOLBY NR SYSTEM

The Dolby NR system functions so that it automatically increases recording levels of medium and high frequencies when the recording signal level is lower than the specified level (encoding), and automatically reduces the output level to the normal level during playback (decoding). In this way, the tape hiss noise is remarkably reduced without affecting the sound quality. The Dolby NR system used in your cassette deck improves S/N ratio by about 5 dB at 1kHz and about 10 dB at 10 kHz B-type and by about 20 dB on the most frequency range in C-type. Furthermore C-type has the anti-saturation network which reduces the affects of high frequency saturation, improving high range frequency response.

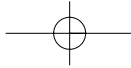
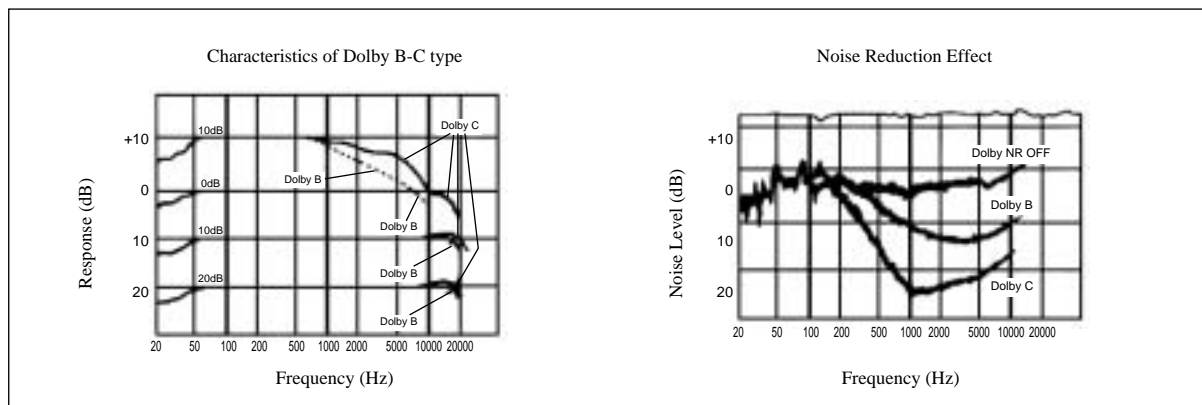

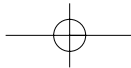

- Dolby noise reduction and HX Pro headroom extension manufactured under license from Dolby Laboratories Licensing Corporation. HX Pro originated by Bang and Olufsen.
- "Dolby", the double-D symbol, and "HX Pro" are trademarks of Dolby Laboratories Licensing Corporation.

NOTES ON CASSETTE TAPE

- Before loading a cassette tape, take up the slack in the tape to prevent it from becoming entangled around the capstan.

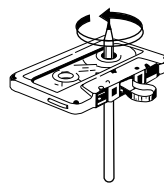

- After the recording has been finished, remove the tab to prevent the recorded contents from being erased or rerecorded on accidentally.

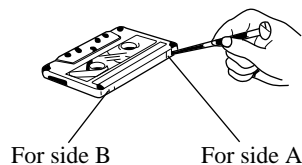

- To rerecord after tabs have been removed, cover with adhesive tape.

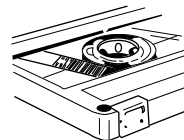

- Do not store the tapes in direct sunlight or near equipment that generates heat. Keep the tapes away from any magnetic fields.
- Do not touch the tape surface. Store the tapes in their cases after use. Dust can cause contamination of the heads resulting in noise.

CLEANING THE HEAD SECTION

Clean the head section about every 10 hours of use. Use a commercially available head cleaning tape.

- For better recordings, you should clean the head section before every recording.
- After cleaning the head section, do not load a tape until the cleared section is completely dry.

DEMAGNETIZING THE HEAD

Demagnetize the recording/playback head about every 10 hours of use with a commercially available demagnetizer so that the magnetized head may not cause the sound to be deteriorated.

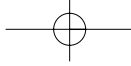

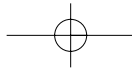

5707-04647-001-0
(9007018991)

